

INSTRUCTION MANUAL

L-3866/67USB

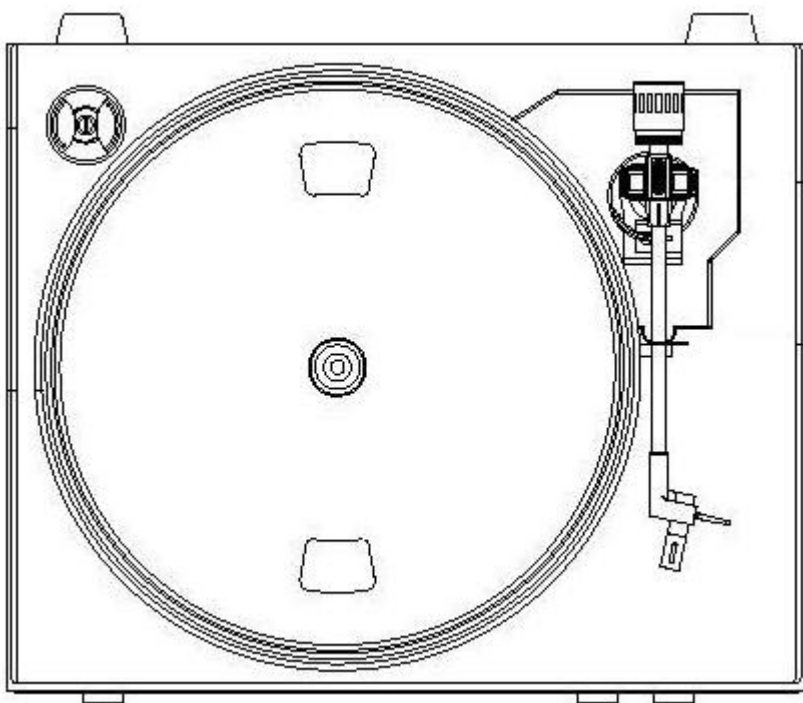

CONTENTS

CONTENTS -----	2
DESCRIPTION -----	3,4
INITIAL STARTING-UP -----	5
Main Connection	
Amplifier Connection-----	5
Playing a record-----	5
MAINTENANCE -----	6
To replace the stylus-----	6
To disassemble the cartridge-----	6
To install new pick-up head-----	6
Important recommendations-----	6
Audacity Software Instruction -----	7-20

DESCRIPTION

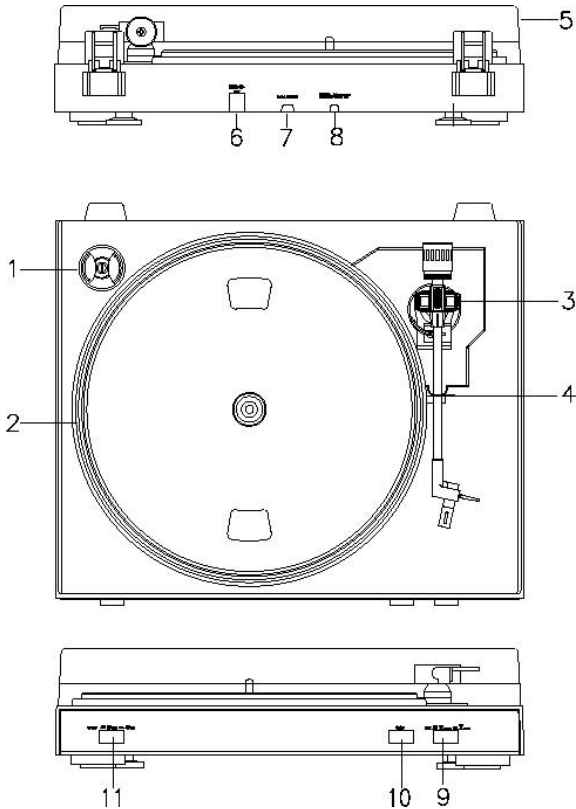

1. **Adapter:**
Use this adapter when playing 45 RPM records.
2. **Platter:**
Platter change in the record will be placed here
3. **Tonearm**
4. **Tonearm Lock:**
Use this lock to keep the tonearm in place when not in use.
5. **Dust Cover:**
Use this to protect the turntable from exposure to dust. The cover may be opened or removed during use, but should remain closed when the turntable is not in use.
6. **USB port:**
 - With Full-Speed Transceivers
 - Fully Compliant With USB 1.1 Specification

Connect to PC for editing the music with your favorite digital editing software, if you need the information of free editing software; please check the website <http://audacity.sourceforge.net/> , and check the attached software instruction.

7. Signal Connectors:

Use these to connect the turntable to the mixer or amplifier in your sound system.

8. Power Cord:

Connect this cord to a grounded AC outlet of the proper voltage.

9. Arm Lift Button

10. Stop Button

11. Speed Button:

Button locked 45rpm

Button unlocked 33 rpm

INITIAL STARTING-UP

MAINS CONNECTION

Ensure that the mains voltage of your home corresponds to the operating voltage of the unit. Your unit is ready to be connected to a mains voltage of 110V/60Hz or 220V/50Hz.

AMPLIFIER CONNECTION

Connect audio plugs to Alert input on your mixer or amplifier:

- Red plug into R/H channel input.
- White plug into L/H channel input.

Playing a record

- Remove the Dust cover from the turntable.
- Place the record of your choice on the turntable. If it is a 45 rpm, do not forget to place the adaptor on the record spindle.
- Choose the desired playing speed:
 - 33 rpm -> button unlocked
 - 45 rpm-> button locked.
- Release the Tone-arm lock.
- Push in the arm lift button (tone-arm will go up)
- Place the cartridge vertically over the first track of the record the turntable starts turning
- Push out the arm lift button (tone-arm will lower record starts playing)
- When the record is over, the tone-arm returns to its rest and the turntable starts turning.

Remark: While the record is ON, If you wish to:

Stop the record while its playing

- Press the stop button; the cartridge comes up and returns to its rest; the turntable stops turning.
- Replace the protective cap on the stylus
Close the tone-arm lock.

MAINTENANCE

TO REPLACE THE STYLUS (FIG.A)

- Put the rest clip on the pick-up arm.
- Pull the stylus in the direction of arrow (A) and remove it.
- Put in the new stylus following the reverse procedure.

TO DISASSEMBLE THE CARTRIDGE (FIG.B)

- Put the rest clip into the pick-up arm.
- Remove the stylus (see section above).
- Release the pick-up head by pushing the cartridge in the direction of arrow.
- Disconnect the three cables link wires at the level of the pick-up head.

TO INSTALL NEW CARTRIDGE

- Connect the three link wires as shown in figure.
- Push the cartridge into headshell
- Re-position the stylus

IMPORTANT RECOMMENDATIONS

We advise you to clean your records using a rag impregnate with an antistatic product for maximum enjoyment of your records and also to make them last.

We would also point out that for the same reason your stylus should be replaced periodically (approximately every 250 hours)

Dust the stylus from time to time using a very soft brush dipped in alcohol (brushing from back to front of the cartridge)

WHEN TRANSPORTING YOUR RECORD PLAYER DO NOT FORGET TO:

- Replace the protective cap on the stylus.
- Put the rest clip into the pick-up arm.

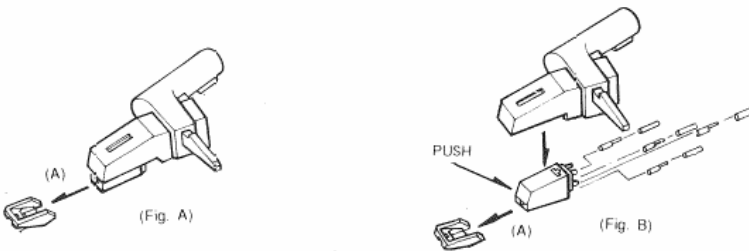

Audacity Quick Guide

For the complete manual please check <http://audacity.sourceforge.net/help/documentation?lang=en>

Before Starting the Software

Make sure that your USB turntable is plugged into the computer and both the computer and the turntable are plugged in and on.

To Install Software (PC)

1. Plug in your turntable to an AC outlet and connect the USB port on the Turntable to the USB port of your computer.
2. Turn on the power switch to your turntable.
3. Windows system will detect a new device and that it is available to use.
4. Insert the CD that came with your USB turntable.
5. Run the file “audacity-win-1.2.6.exe” to install Audacity software. Once installed, run the Audacity program.

To Install Software (MAC)

1. Insert the included CD
2. Open the CD icon on the desktop.
3. Drag the installation folder for audacity to your hard drive. We recommend that you move the folder to your “Applications” folder.
4. A window will come up which shows the files copying.
5. EJECT the CD.
6. Open “Audacity” from where you moved it to on your hard drive.

Software Configuration

1. Click on Microphone in the drop down menu and select “Stereo Mix”

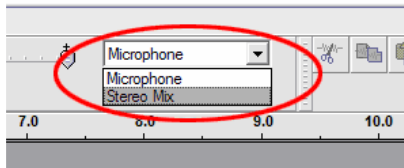

Figure 1: Select Stereo Mix

2. Select the “Edit” menu and then “Preferences”

Select the USB audio device under the “Recording” selection as shown. Select “Software Playthrough” to hear the audio while recording.

Note: The USB Turntable may show up with a different name in Windows system.. This may depend on your computer model and operating system. 99% of the time it will contain “USB” in the Name.

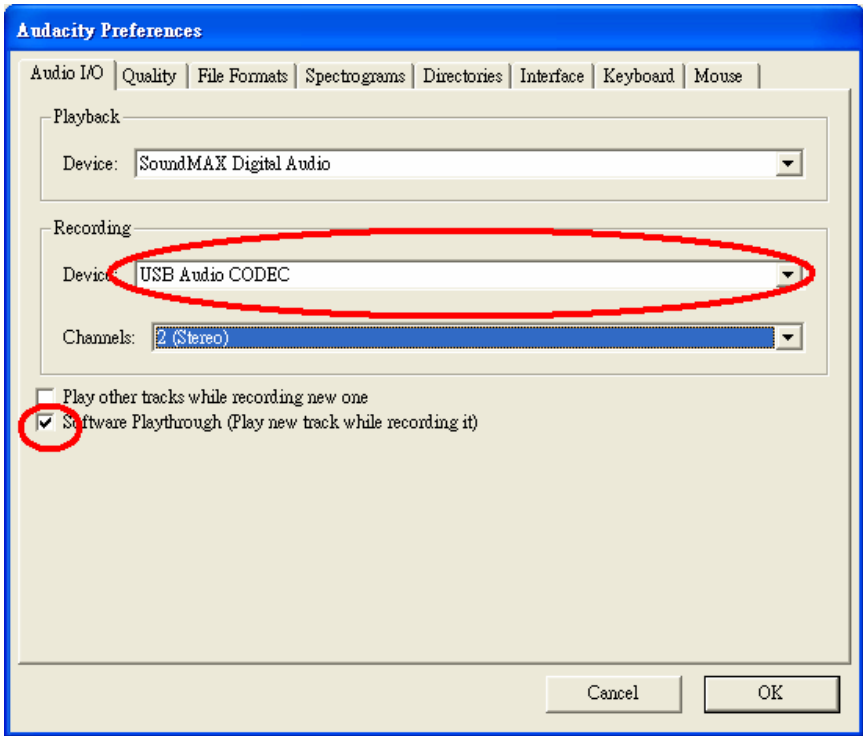
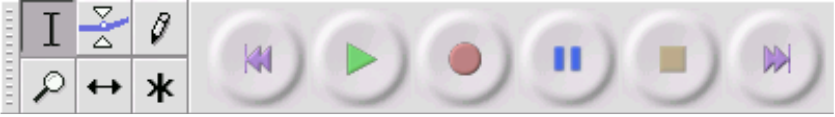







Figure 2: Select USB Audio Device from Preferences

After completed the above settings, you are ready for recording.







If you are still having difficulty finding the USB Turntable, try to check your system settings or control panel to adjust audio input settings from the sound control panel. .

Toolbars



-  Selection tool - for selecting the range of audio you want to edit or listen to.
-  Envelope tool - for changing the volume over time.
-  Draw tool - for modifying individual samples.
-  Zoom tool - for zooming in and out.
-  Timeshift tool - for sliding tracks left or right.
-  Multi tool - lets you access all of these tools at once depending on the location of the mouse and the keys you are holding down.

Audio Control Buttons

-  Skip to Start - moves the cursor to time 0. If you press Play at this point, your project will play from the beginning.
-  Play - starts playing audio at the cursor position. If some audio is selected, only the selection is played.
-  Loop - if you hold down the Shift key, the Play button changes to a Loop button, which lets you keep playing the selection over and over again.
-  Record - starts recording audio at the project sample rate (the sample rate in the lower-left corner of the window). The new track will begin at the current cursor position, so click the "Skip to Start" button first if you want the track to begin at time 0.
-  Pause - temporarily stops playback or recording until you press pause again.
-  Stop - stops recording or playing. You must do this before applying effects, saving or exporting.



Skip to End - moves the cursor to the end of the last track.

Edit Toolbar



All of the buttons on this toolbar perform actions - and with a couple of exceptions, they're all just shortcuts of existing menu items to save you time. Holding the mouse over a tool will show a "tooltip" in case you forget which one is which.



Cut



Copy



Paste



Trim away the audio outside the selection



Silence the selected audio



Undo



Redo (repeat last command).



Zoom In



Zoom Out



Fit selection in window - zooms until the selection just fits inside the window.



Fit project in window - zooms until all of the audio just fits inside the window.

Track Pop-Down Menu

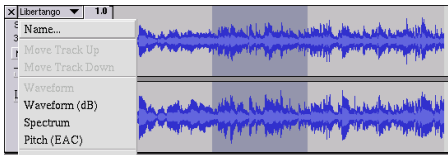

The Track Pop-Down Menu appears when you click in a track's title. This lets you access a few special commands that apply to individual tracks.

Name... - lets you change the name of the track.

Move Track Up - exchange places with the track above this one.

Move Track Down - exchange places with the track below this one.

Waveform - sets the display to Waveform - this is the default way of visualizing audio.

Waveform (dB) - similar to Waveform, but on a logarithmic scale, measured in decibels (dB).

Spectrum - display the track as a spectrogram, showing the amount of energy in different frequency bands.

Pitch (EAC) - highlights the contour of the fundamental frequency (musical pitch) of the audio, using the Enhanced Autocorrelation (EAC) algorithm.

Mono - makes this track a mono track, meaning it is played out of just one speaker, or played out of the left and right speakers equally.

Left Channel - makes this track come out of only the left speaker.

Right Channel - makes this track come out of only the right speaker.

Make Stereo Track - if there is another track below this one, joins them to make a single stereo track, with the top track representing the left speaker, and the bottom track representing the right speaker. When tracks are joined into a stereo pair, all edits automatically apply to both the left and right channel.

Split Stereo Track - if the selected track is a stereo track (a pair of left and right tracks joined together as a single track), this operation splits them into two separate tracks that you can modify and edit independently.

Set Sample Format - this determines the quality of the audio data and the amount of space it takes up. 16-bit is the quality used by audio CD's and is the minimum quality that Audacity uses internally (8-bit audio files are automatically converted when you open them). 24-bit is used in higher-end audio hardware. 32-bit *float* is the highest quality that Audacity supports, and it is recommended that you use 32-bit float unless you have a slow computer or are running out of disk space.

Set Rate - sets the number of samples per second of the track. 44100 Hz is used by audio CDs. Tracks can have different sample rates in Audacity; they are automatically resampled to the project sample rate (in the lower-left corner of the window).

[MENU]

File Menu

New - creates a new empty window

Open... - opens an audio file or an Audacity project in a new window (unless the current window is empty). To add audio files to an existing project window, use one of the Import commands in the Project menu.

Close - closes the current window, asking you if you want to save changes. On Windows and Unix, closing the last window will quit Audacity, unless you modify this behavior in the Interface Preferences.

Save Project - saves everything in the window into an Audacity-specific format so that you can save and quickly continue your work later. An Audacity project consists of a project file, ending in ".aup", and a project data folder, ending in "_data". For example, if you name your project "Composition", then Audacity will create a file called "Composition.aup" and a folder

called Composition_data. Audacity project files are not meant to be shared with other programs - use one of the Export commands (below) when you are finished editing a file.

Save Project As... - same as Save Project (above), but lets you save a project as a new name.

Recent Files ... - brings up a list of files you have recently opened in audacity to be re-opened quickly.

Export As WAV... - exports all of the audio in your project as a WAV file, an industry-standard format for uncompressed audio. You can change the standard file format used for exporting from Audacity by opening the File Format Preferences . Note that exporting will automatically mix and resample if you have more than one track, or varying sample rates. See also File Formats.

Export Selection As WAV... - same as above, but only exports the current selection.

Export as MP3... - exports all of the audio as an MP3 file. MP3 files are compressed and therefore take up much less disk space, but they lose some audio quality. Another compressed alternative is Ogg Vorbis (below). You can set the quality of MP3 compression in the File Format Preferences. See alsoMP3 Exporting.

Export Selection As MP3... - same as above, but only exports the current selection.

Export as Ogg Vorbis... - exports all of the audio as an Ogg Vorbis file. Ogg Vorbis files are compressed and therefore take up much less disk space, but they lose some audio quality. Ogg Vorbis files tend to take up a little less disk space than MP3 for similar compression quality, and Ogg Vorbis is free from patents and licensing restrictions, but Ogg Vorbis files are not as widespread. You can set the quality of Ogg compression in the File Format Preferences.

Export Selection As Ogg Vorbis... - same as above, but only exports the current selection.

Export Labels... - if you have a Label Track in your project, this lets you export the labels as a text file. You can import labels in the same text format using the "Import Labels..." command in the Project Menu.

Export Multiple... - lets you split your project into multiple files all in one step. You can either split them vertically (one new file per track), or horizontally (using labels in a Label Track to indicate the breaks between exported files).

Page Setup - configure how Audacity will print out the track waveforms using the Print option, and what printer to use.

Print - Print out the main window view from audacity showing the tracks and waveforms.

Exit (Quit) - closes all windows and exits Audacity, prompting you to save any unsaved changes first.

Edit Menu

Undo - This will undo the last editing operation you performed to your project. Audacity supports full unlimited undo - meaning you can undo every editing operation back to when you opened the window.

Redo - This will redo any editing operations that were just undone. After you perform a new editing operation, you can no longer redo the operations that were undone.

Cut - Removes the selected audio data and places it on the clipboard. Only one "thing" can be on the clipboard at a time, but it may contain multiple tracks.

Copy - Copies the selected audio data to the clipboard without removing it from the project.

Paste - Inserts whatever is on the clipboard at the position of the selection or cursor in the project, replacing whatever audio data is currently selected, if any.

Trim - Removes everything to the left and right of the selection.

Delete - Removes the audio data that is currently selected without copying it to the clipboard.

Silence - Erases the audio data currently selected, replacing it with silence instead of removing it.

Split - Moves the selected region into its own track or tracks, replacing the affected portion of the original track with silence. See the figure below:

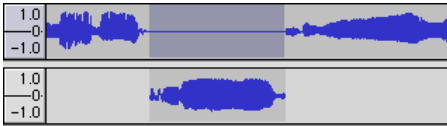

Duplicate - Makes a copy of all or part of a track or set of tracks into new tracks. See the figure below:

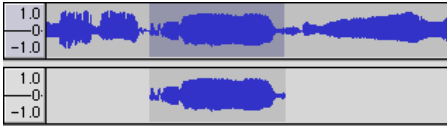

Select ... > All - Selects all of the audio in all of the tracks in the project.

Select ... > Start to Cursor - Selects from the beginning of the selected tracks to the cursor position.

Select ... > Cursor to End - Selects from the cursor position to the end of the selected tracks.

Find Zero Crossings - Modifies the selection slightly so that both the

left and right edge of the selection appear on a positive-slope zero crossing. This makes it easier to cut and paste audio without resulting in an audible clicking sound.

Selection Save - Remembers the current selection (or cursor position), allowing you to restore it later.

Selection Restore - Restores the cursor position to the last position saved by "Selection Save".

Move Cursor ... > to Track Start - Moves the cursor to the start of the current track.

Move Cursor ... > to Track End - Move the cursor to the end of the currently selected track.

Move Cursor ... > to Selection Start - Moves the cursor to the start of the current selection.

Move Cursor ... > to Selection End - Moves the cursor to the end of the current selection.

Snap-To ... > Snap On - Enable Snap-To mode. When Snap-To mode is enabled, the selection will be constrained to the nearest interval on the time scale, by default the nearest second. So if you click and drag from 4.2 seconds to 9.8 seconds, it will result in a selection from 4 seconds to 10 seconds, exactly. You can change the units that are snapped to using the "Set Selection Format" option in the View Menu .

Snap-To ... > Snap Off - Turns Snap-To mode off letting you select arbitrary ranges of time

Preferences... - opens the Preferences dialog.

View Menu

Zoom In - Zooms in on the horizontal axis of the audio, displaying more detail about less time. You can also use the zoom tool to zoom in on a particular part of the window.

Zoom Normal - Zooms to the default view, which displays about one inch per second.

Zoom Out - Zooms out, displaying less detail about more time.

Fit in Window - Zooms out until the entire project just fits in the window.

Fit Vertically - Resizes all of the tracks vertically so they all fit inside of the window (if possible).

Zoom to Selection - Zooms in or out so that the selection fills the window.

Set Selection Format - lets you choose the formatting that is displayed at the bottom of the window indicating the current selection time. Options include film, video, and audio CD frames, seconds + samples, or pure time. If

you turn on Snap-To mode in the Edit Menu, the selection will snap to the frames or other quantization you have selected in this menu.

History... - Brings up the history window. It shows all the actions you have performed during the current session, including importing. The right-hand column shows the amount of hard disk space your operations used. You can jump back and forth between editing steps quite easily by simply clicking on the entries in the window, the same as selecting Undo or Redo many times in a row. You can also discard Undo history to save disk space. The history window can be kept open while you work.

Float Control Toolbar - moves the Control Toolbar out of the window and into its own floating window, so you can position it wherever you want. The menu item changes to **Dock Control Toolbar**, which you can use to put the toolbar back into the main window.

Float Edit Toolbar - moves the Edit Toolbar out of the window and into its own floating window, so you can position it wherever you want. The menu item changes to **Dock Edit Toolbar**, which you can use to put the toolbar back into the main window.

Float Meter Toolbar - does the same thing for audacity's VU meters which you use to set recording levels and adjust playback.

Float Mixer Toolbar - moves the Mixer Toolbar out of the window and into its own floating window as above.

Project Menu

Import Audio... - This command is used to import audio from a standard audio format into your project. Use this command if you already have a couple of tracks and you want to add another track to the same project, maybe to mix them together. You cannot use this option to import Audacity Projects. The only way to combine two Audacity Projects is to open them in separate windows, then copy and paste the tracks.

Import Labels... - This command takes a text file which contains time codes and labels, and turns them into a Label Track.

Import MIDI... - This menu command imports MIDI files and puts them into a MIDI Track. Audacity can display MIDI files, but *cannot play, edit, or save them yet.*

Import Raw Data... - This menu command allows you to open a file in virtually any uncompressed format. When you select the file, Audacity will analyze it and try to guess its format. It will guess correctly about 90% of the time, so you can try just pressing "OK" and listening to the result. If it is not correct, however, you can use the

options in the dialog to try some other possible encodings. At the beginning of your imported track(s), you may notice a little bit of noise. This is probably the file's header, which Audacity was not able to parse. Just zoom in and select the noise with the Selection Tool, and then choose Delete from the Edit Menu.

Edit ID3 Tags... - Opens a dialog allowing you to edit the ID3 tags associated with a project, for MP3 exporting.

Quick Mix - This command mixes all of the selected tracks together. If you are mixing stereo tracks, or mixing tracks that are marked as Left or Right channel, the result will be a stereo track (two channels), otherwise the result will be mono. Your tracks are implicitly mixed whenever you hit the Play button and whenever you export. This command offers a way to do it permanently and save the results to disk, saving on playback resources. Note that if you try to mix two very loud tracks together, you may get clipping (it will sound like pops, clicks, and noise). To avoid this, drag the gain slider on the tracks down to reduce their volume before mixing.

New Audio Track - This creates a new empty Audio Track. This command is rarely needed, since importing, recording, and mixing automatically create new tracks as needed. But you can use this to cut or copy data from an existing track and paste it into a blank track. If

that track was at a non-default rate then you may need to use Set Rate from the Track Pop-Down menu to set the correct sample rate.

New Stereo Track - same as above, but creates a stereo track. You can also create a stereo track by joining two tracks using the track pop-down menu.

New Label Track - This creates a new Label Track, which can be very useful for textual annotation.

New Time Track - This creates a new Time Track, which is used to vary the speed of playback over time.

Remove Tracks - This command removes the selected track or tracks from the project. Even if only part of a track is selected, the entire track is removed. You can also delete a track by clicking the X in its upper-left corner. To cut out only part of the audio in a track, use Delete or Silence.

Align Tracks... - All the Align functions work on whole tracks or groups of tracks, not on selections, even if they span across multiple tracks. They all operate by time-shifting tracks (moving them left or right), making it easier to synchronize tracks or get rid of silence at the beginning. The cursor or selection stays in the same place unless you use "Align and move cursor...", below:

Align and move cursor... - same as the functions above, except that the cursor or selection is moved along with the tracks. That allows you to shift the tracks without losing your relative place.

Add Label at Selection - This menu item lets you create a new label at the current selection. You can title the label by typing with the keyboard and then hitting "Enter" when you're done.

Add Label at Playback Position - This menu item lets you create a new label at the current location where you are playing or recording. Do this if you want to mark a certain passage while you're listening to it. You can title the label by typing with the keyboard and then hitting "Enter" or "Return" when you're done. Only available whilst audacity is playing.

Generate Menu

If you choose an item from the Generate menu when there are no tracks in a project, a new track is created. Otherwise, the current track is used.

If a track is selected and the cursor is placed in a single place in the track audio is inserted at the cursor position. The default duration is 30 seconds.

The audio created will replace the any selection, otherwise it is inserted into the track, shifting up later parts of the track.

way to quickly apply the same effect to many different parts of a file.

Silence - inserts silence

Tone... - you can create a Sine wave, Square wave, or Sawtooth wave.

White Noise - inserts random audio samples, which sounds like pure static.

Any items which appear after these three built-ins are VST, Ladspa, or Nyquist plug-ins. It is possible for a poorly written plug-in to crash Audacity, so always save your work before using a plug-in. Note that any effect that doesn't take any audio as input will automatically be placed in the Generate menu.

Effect Menu

The items in this menu only work when you have audio selected. Audacity does not have any real-time effects; you must select the audio, apply the effect, and then listen to the results. Most effects have a Preview button. Clicking on this button plays up to three seconds of audio, allowing you to hear what it will sound like after the effect is applied. This is useful for fine-tuning the effect parameters.

Repeat Last Effect - selecting this command is a shortcut to applying the most recent effect with the same settings. This is a convenient

Amplify - changes the volume of the selected audio. If you click the "Allow clipping" checkbox, it will let you amplify so much that the audio ends up beyond the range of the waveform, and is clipped (distorted). The default value when you open the effect is to amplify so that the loudest part of the selection is as loud as possible without distortion.

Bass Boost - enhances the bass frequencies in the audio.

Change Pitch - changes the pitch/frequency of the selected audio without changing the tempo. When you open the dialog, the starting frequency is set to Audacity's best guess as to the frequency of the selection. This works well for recordings of singing or musical instruments without background noise. You can specify the pitch change in one of four different ways: musical note, semitones, frequency, or percent change.

Change Speed - changes the speed of the audio by resampling. Making the speed higher will also increase the pitch, and vice versa. This will change the length of the selection.

Change Tempo - changes the tempo (speed) of the audio without

changing the pitch. This will change the length of the selection.

Compressor - compresses the dynamic range of the selection so that the loud parts are softer while keeping the volume of the soft parts the same. You can optionally normalise the recording afterwards, resulting in the entire piece having higher perceived volume.

Echo - very simple effect that repeats the selection with a decay, sounding like a series of echos. This effect does not change the length of the selection, so you may want to add silence to the end of the track before applying it (using the Generate Menu).

Equalization - Boost or reduce arbitrary frequencies. You can select one of a number of different curves designed to equalize the sound of some popular record manufacturers, or draw your own curve.

Fade In - fades the selection in linearly

Fade Out - fades the selection out linearly

FFT Filter - similar to Equalization, lets you enhance or reduce arbitrary frequencies. The curve here uses a linear scale for frequency.

Invert - Flips the waveform vertically, the same as a phase inversion in the analogue domain.

Noise Removal - This effect lets you clean up noise from a recording. First, select a small piece of audio that is silent except for the noise, select "Noise Removal", and click on the "Get Noise Profile" button. Then select all of the audio you want filtered select "Noise Removal" again, and click the "Remove Noise" button. You can experiment with the slider to try to remove more or less noise. It is normal for Noise Removal to result in some distortion. It works best when the audio signal is much louder than the noise.

Normalize - allows you to correct for DC offset (a vertical displacement of the track) and/or amplify such that the maximum amplitude is a fixed amount, -3 dB. It's useful to normalize all of your tracks before mixing. If you have a lot of tracks, you may then need to use the track gain sliders to turn some down.

Nyquist Prompt - for advanced users only. Allows you to express arbitrary transformations using a powerful functional programming language. See the Nyquist section of the Audacity website for more information.

Phaser - the name "Phaser" comes from "Phase Shifter", because it works by combining phase-shifted signals with the original signal. The movement of the phase-shifted signals is controlled using a Low Frequency Oscillator (LFO).

Repeat - repeats the selection a certain number of times. This operation is quite fast and space-efficient, so it is practical to use it to create nearly-infinite loops.

Reverse - This effect reverses the selected audio temporally; after the effect the end of the audio will be heard first and the beginning last.

Wahwah - uses a moving bandpass filter to create its sound. A low frequency oscillator (LFO) is used to control the movement of the filter throughout the frequency spectrum. Adjusts the phase of the left and right channels when given a stereo selection, so that the effect seems to travel across the speakers.

Plugins 1 to 15 ... etc. These submenus contain any VST, Ladspsa, or Nyquist plug-ins loaded by audacity. It is possible for a poorly written plug-in to crash Audacity, so always save your work before using a plug-in effect.

Analyze Menu

Plot Spectrum - To use this feature, first select a region of audio from a single track, then select "Plot Spectrum". It opens up a window that displays the Power Spectrum of the audio over that region, calculated using the Fast Fourier Transform. The graph represents how much energy is in each frequency. As you move the mouse over the display, it shows you the

nearest peak frequency. This window can also display other common functions that are calculated using the Fast Fourier Transform, including three versions of the Autocorrelation function. The Enhanced Autocorrelation function is very good at identifying the pitch of a note.

The Analyze menu is intended for effects and plug-in effects that do not modify the audio, but simply open a dialog with some descriptive information. Audacity also supports Analyze commands that create annotations in a Label Track.

Help Menu

About Audacity - displays the version number and credits. If you compiled Audacity yourself, check here to verify which optional modules were successfully compiled in.

Contents ... - opens this reference guide in a searchable form.